

# Key Points of Installation Technology and Analysis of Energy Saving Measures on HVAC Equipment

Ruan Xiaolong<sup>1\*</sup>, Yin Yisong<sup>2</sup>

<sup>1</sup>CHONGQING INFORMATION TECHNOLOGY DESIGNING CO. LTD, Chongqing 400000, China;

<sup>2</sup>Shanghai Fengsi Chengjie Architecture Design & Research Institute CO., Ltd Chongqing 400000 China.

**Abstract:** HVAC equipment is very concerned in the current equipment operation process. Its safety, reliability and comfort will have a greater impact on the production and life of common people. In some projects, there are some problems in the installation of HVAC equipment, such as imperfect installation scheme, low installation quality and random selection of equipment parameters. These seriously affect the normal operation of the equipment, and it is not easy to achieve energy saving of HVAC equipment. In the future installation of HVAC equipment, it is necessary to continuously optimize the HVAC equipment installation system, fully compare the reliability and feasibility of the equipment installation scheme, and strengthen the application of energy-saving technology of HVAC equipment. In this way, the use cost of the equipment can be reduced and the comprehensive quality of the equipment can be improved. Therefore, this paper discusses this further and puts forward reasonable suggestions.

**Keywords:** HVAC equipment; Installation; Technology; Energy saving

**Publication date:** May, 2020

**Publication online:** 31 May, 2020

**Corresponding author:** Ruan Xiaolong, woshiyizhixiaoq@ sina.com

Different from the previous situation, the installation and energy saving of HVAC equipment must be scientifically adjusted based on different ideas and methods, especially to better meet the regional needs. As the number of domestic population are increasing continuously and the places and functions that need equipment services are also being refined, the

installation and energy saving of HVAC equipment should stand in different angles to make better innovation. We should not only keep enough stability and safety in installation technology, but also make better innovation in energy-saving means, so as to improve production and living standards.

## 1 Installation of HVAC equipment

### 1.1 Strengthening installation preparation

In the process of engineering construction and development at this stage, the installation of HVAC equipment can have a very high impact and create a significant comprehensive value. However, in order to improve the installation level of HVAC equipment, scientific adjustment must be made in terms of installation preparation. In this way, we can promote the comprehensive work deployment and arrangement, move forward in the direction of rationalization, and reduce potential risks and deficiencies. First of all, for the installation design of HVAC equipment, it is necessary to keep highly clear about the content of its own basic installation, as shown in the following figure 1:

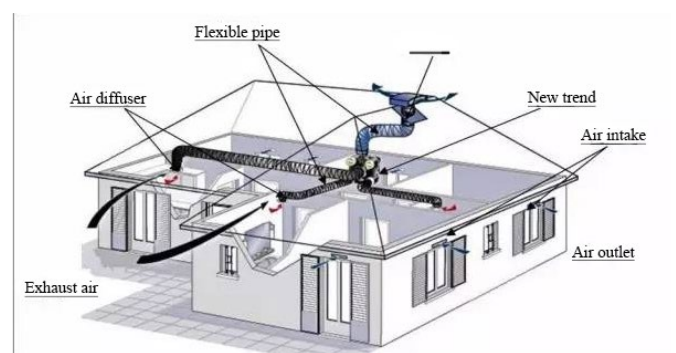

**Figure 1.** Basic installation of HVAC equipment

Because the HVAC equipment itself has a strong particularity and can have a great impact on the internal comfort enhancement of the building, we must make effective improvement in the installation preparation. And good arrangements should be made for basic equipment, various materials and auxiliary tools. This can promote the follow-up work to be perfected in the direction of rationalization. In the comprehensive treatment of various deficiencies, efforts have been made to get better achievements. Secondly, the preparation of HVAC equipment should adhere to the investigation and research based on the installation engineering, as well as its own ancillary areas. At different levels, we can improve the shortcomings caused by restrictive conditions. In the process of specific equipment installation and operation, we can achieve better results.

### 1.2 Perfecting the installation system

From an objective point of view, the installation of HVAC equipment should be carried out from a long-term perspective. Although the installation is not particularly difficult, there are many factors that need to be paid attention to. This requires us to get better improvement in the perfection level of the installation system, so as to be able to connect the next work operation and lay a solid foundation. For all kinds of potential hazards, we need to make effective screening. For example, during the installation of brackets, it has a great impact on the bearing capacity for HVAC

equipment. Our common bracket installation is mainly completed through the joint fabrication of section steel and suspender. In this way, not only the bearing capacity can be better improved, but also the normal operation of HVAC equipment can produce better advancing effect. In addition, in the initial stage of the installation of HVAC equipment, the selection of hanging-type bracket can be completed by the fixing way of penetrating floor. This can not only greatly improve the safety of HVAC equipment, but also greatly improve the long-term operation of the equipment<sup>[1]</sup>. At present, the installation of HVAC equipment has attracted great attention in this industry. We need to start from different ideas and standards to reduce potential risks and deficiencies.

### 1.3 Enhancing simplified installation

In the current process of research, development and innovation of HVAC equipment in China, the installation work must be considered and analyzed from different ideas. If we continue to install and operate in a miscellaneous way, we will not only fail to achieve the expected effect, but also cause serious loopholes in equipment application, which will cause various kinds of very serious losses. To a large extent, the application of simplified installation can lay a solid foundation for the long-term and stable operation of HVAC equipment. Moreover, the convenience of maintenance can be improved in the meantime, as shown in the following figure 2:

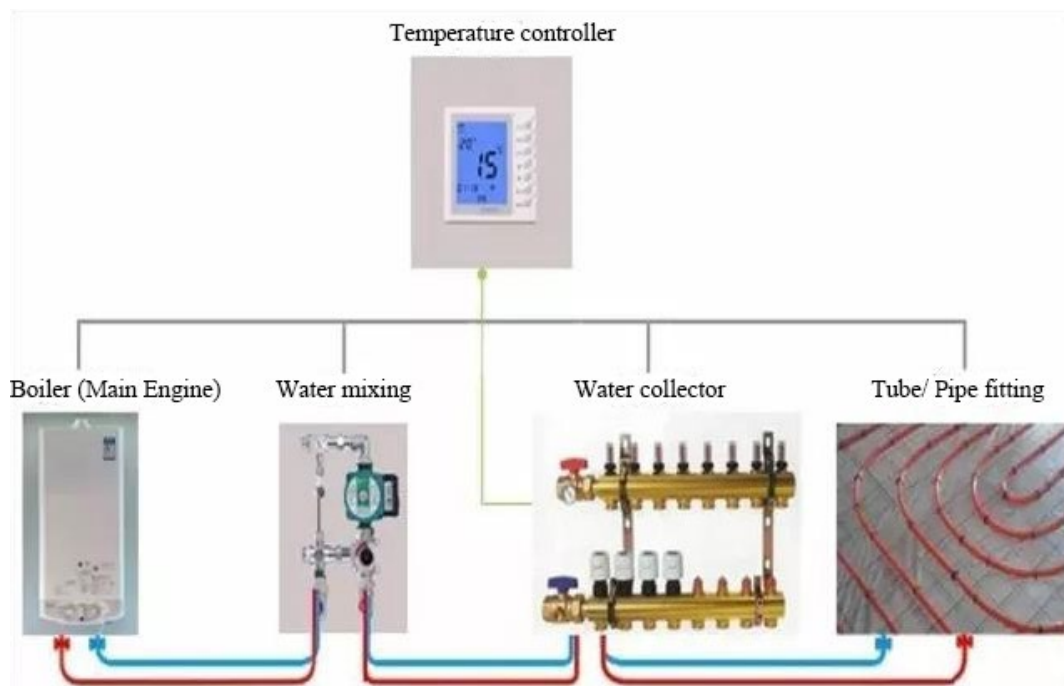

Figure 2. Simplified installation mode for HVAC equipment

It can be seen from the figure that in the current household application process, the simplified installation mode of HVAC equipment can be discussed and analyzed from different perspectives. For the practical application of the equipment, as well as the innovation of parts, or the improvement of equipment performance, it can achieve better results. However, in the operating process of simplified installation, the practical application effect of HVAC equipment should be fully considered, which cannot be completely completed according to the theoretical mode. At this time, the needs of the owner should be fully considered, so as to provide more support for the long-term development of HVAC equipment and the adjustment of its own installation<sup>[2]</sup>.

## 2 Energy saving technology of HVAC equipment

### 2.1 Implementing comprehensive energy saving

After the advent of the new era, the energy-saving work of HVAC equipment has aroused strong discussion in this industry. China is a country with a large population, and the demand for HVAC equipment is constantly increasing. As the energy consumption in this aspect is constantly improving, it is also essential for the comprehensive energy-saving deployment and arrangement of HVAC equipment. Only in the continuous progress of energy-saving technology, can we achieve better development results in the implementation of the follow-up work. (As shown in Figure 3.)

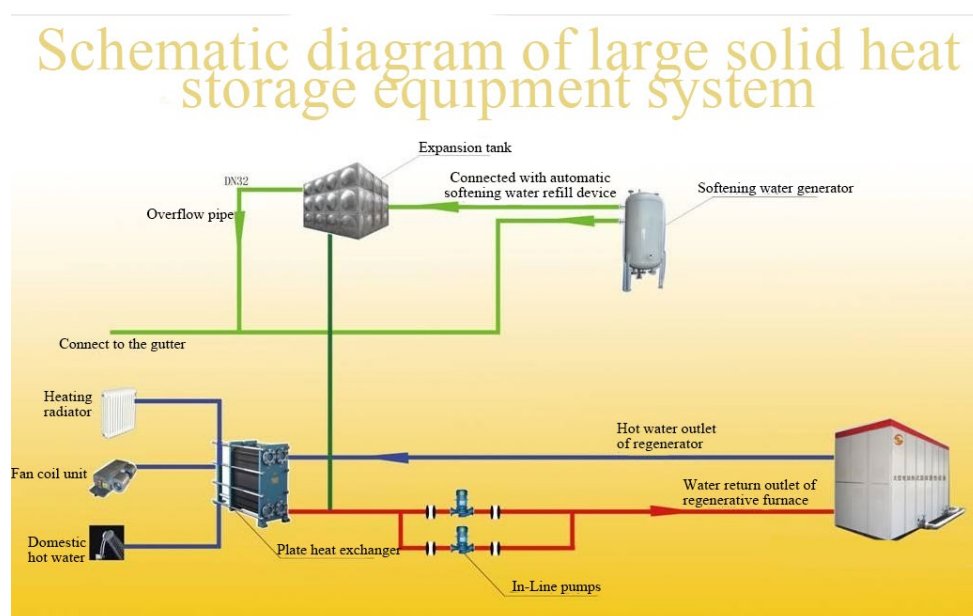

Figure 3. Schematic diagram of large solid heat storage equipment system

It can be seen from the Figure 3. that the operation efficiency and operation quality of the equipment have achieved better developmental results after making good application of energy-saving technology for HVAC equipment. All aspects of work arrangement can create higher value. Different from the previous situation, China begins to improve the application and R&D of HVAC equipment towards the original innovation. The advantage of this energy-saving is that it cannot only promote the actual operation level of HVAC equipment to a great extent, but also effectively extend the service life of the equipment to avoid the shortage caused by frequent replacement of the equipment<sup>[3]</sup>. In view of the future work progress, we can continuously make greater progress in the creation of comprehensive benefits.

### 2.2 Optimization of maintenance system and utilization and recovery of heat energy

In our country, the energy conservation of HVAC equipment must be adjusted from many aspects. All aspects of work implementation and innovation need to be continuously improved in combination with actual needs. It is necessary to make a good optimization in the maintenance system and make effective improvement in the recovery and utilization of heat energy. It can promote the energy-saving innovation of HVAC equipment from different levels, and promote the comprehensive performance of future work. It is worth noting that the application of this energy-saving technology can produce good promotion effect for future development and deployment. In order to

effectively reduce the heat loss of construction projects, we should optimize and improve the maintenance system structure, reduce the design area of external windows, and do a good job in sunshade protection. At the same time, the appropriate shape coefficient should be optimized to effectively improve the thermal resistance of the maintenance system, and the building orientation should be well designed according to the environmental characteristics and regional distribution, so as to promote the good improvement of the thermal insulation function of the project, and thus effectively reduce the energy consumption of the air conditioning and heating system. The main energy consumption of heat and cold sources in HVAC system accounts for about 50% of the total energy consumption. Therefore, it is very important to recover the condensing heat of refrigeration unit. This kind of heat exchange system device shall be effectively combined with domestic water. After the refrigerant is compressed, it has a higher temperature level, which can heat the water to the standard bath temperature that people bear.

### **2.3 Application of frequency control and innovation of energy-saving practice**

At present, the energy saving of HVAC equipment can basically be improved according to the expected ideas, and the overall value that can be created is relatively significant. But considering the future work, we need to better deal with the problems in all aspects. Therefore, the arrangement of energy-saving work cannot be concentrated on a single content. The application of frequency control can improve the energy saving level of HVAC equipment. For example, in the operation process of frequency control technology, for large-scale public construction projects, we can improve the energy-saving indicators and increase the main energy-saving ways. The sources of human body's cold and hot feeling are mainly the changes of environment temperature, air humidity, and average radiation standard and so on. But for the traditional air conditioning control measures, a single technical measure cannot achieve the control of the ambient temperature and humidity. The advantage of frequency control technology is that it can carry out common adjustment for a number of technical indicators, so that in the process of reducing energy consumption, it can reach more than 60% of the standard<sup>[4]</sup>.

## **3 Development trend of HVAC equipment**

In the current process of construction and progress in

China, the installation and energy saving level of HVAC equipment have made good progress. And the overall work arrangement doesn't show serious omissions and potential risks. The overall work has obtained higher results. Therefore, for the future development, we need to be cautious. Firstly, in the development of HVAC equipment, we should adhere to good adjustments in the aspects of different technical concepts, equipment maintenance, and daily parts replacement. From different modes, we ensure that the installation and energy saving of HVAC equipment can be completed in accordance with the coordinated mode, reducing internal conflicts and conflicts. Secondly, in the development of HVAC equipment, we should continue to improve the strength of equipment testing. There is the impact of differences in the use of different equipment. And in the long-term using effect, we must get better adjustment. In this way, it can make more outstanding contribution to the follow-up progress of HVAC equipment.

## **Conclusion**

The installation of HVAC equipment and the research of energy-saving technology are constantly toward a higher standard to complete. And its overall economic and social benefits are greatly improved. The overall work arrangement does not cause serious omissions and hidden dangers. In the future, we should continue to improve the self-regulation and innovation of HVAC equipment in accordance with new methods to realize the national energy-saving goal, so as to avoid the recurrence of similar problems.

## **References**

- [1] Huang WH. Key Points of Installation Technology and Analysis of Energy Saving Measures on HVAC Equipment of the Architecture[J]. Sichuan Cement, 2019, (12): 311.
- [2] Luo X. Treatment and Analysis on Vibration Isolation and Noise Prevention of HVAC Equipment Installation[J]. Building Materials and Decoration, 2019, (33): 215-216.
- [3] Li J. Key Points of Installation Technology and Analysis of Energy Saving Measures on HVAC Equipment of the Architecture[J]. Petrochemical Technology, 2019, 26(10): 214 + 216.
- [4] Liu CQ. Discussion on the Installation Construction Technology and Energy-Saving Measures for the Architectural HVAC Equipment[C] . Organizing Committee of <Architectural Science and Technology and Management> . Paper Collection of the Academic Conference of Architectural Science and Technology and Management in March 2014. Organizing Committee of <Architectural Science and Technology and Management> : Beijing Hengsheng Boya International Cultural Exchange Center, 2014: 109 + 69.