

# Analysis of Factors Affecting Logging Quality of Dual Lateral Instruments and Measures

Qiming Gao

<sup>1</sup>Key Laboratory of Exploration Technologies for Oil and Gas Resources, Ministry of Education, Yangtze University, Wuhan, Hubei, 430100, China

<sup>2</sup>Institute of Geophysics and Petroleum Resources, Yangtze University; Wuhan, Hubei, 430100, China

**Abstract:** In order to effectively improve the application value of equipment, the quality of dual-sided instrument logging is more important, but it has several influencing factors. This paper analyzes the working principle of dual lateral instrument logging, and discusses the factors affecting the logging quality of dual-sided instruments and optimization measures, for reference only.

**Keywords:** dual lateral instrument logging; quality; influencing factors; optimization measures

**Publication date:** January, 2019

**Publication online:** 31 January, 2019

**Corresponding Author:** Qiming Gao, kimiougao@icloud.com

## 1 Introduction

The dual lateral instrumentation logging is itself a device for determining the underlying resistivity and the oil and gas layer can be explored by means of the measured data of the underlying resistivity, and the oil and gas saturation is effectively determined, so that the corresponding work can be carried out rationally. In order to ensure the quality of its operation, it is necessary to analyze the general expressions such as the center frequency, the gain at the center frequency, and the quality factor.

## 2 Dual lateral instrument logging working principle

There are 9 basic electrode structures in the dual lateral instrument logging. The main electrode AO is in the

central structure of the device, and 8 electrodes are symmetrically formed on the upper and lower sides of the central structure. Most importantly, each pair of electrodes is short-circuited to complete the connection mode. Further, the electrodes M1, M1' and N1, N1' can perform control of the supervisory electrode on the device, and the deep side is processed to the return electrode and the measurement reference electrode<sup>[1]</sup>. The specific principle is shown in Figure 1.

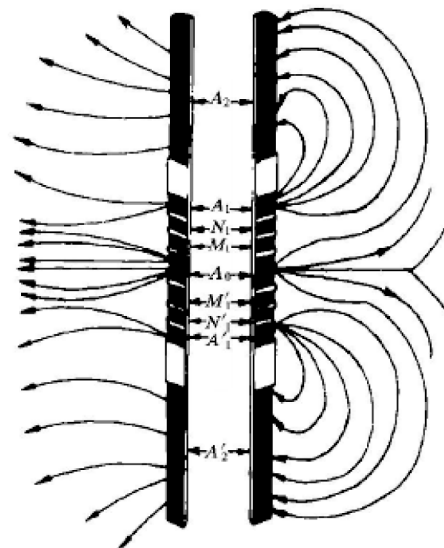

Figure 1. Working principle of dual lateral instrument logging

## 3 Factors affecting the logging quality of dual lateral instruments

In order to effectively improve the quality of the dual-side instrument logging operation, relevant personnel should comprehensively analyze the quality level, implement the systematic quality control mode in combination with

the corresponding content, and comprehensively analyze the influencing factors to implement the corresponding management after rationality<sup>[2]</sup>. Among them, logging circuit and logging SP are all key influencing factors. It is necessary to carry out overall analysis based on specific conditions to ensure that the corresponding line operation level can meet the specific process of application control points and ensure the rationality of the corresponding

analysis<sup>[3]</sup>.

### 3.1 Logging circuit

In the process of dual-sided instrument logging application, the shallow lateral instrument logging power supply circuit is the No. 10 cable core, and the corresponding deep lateral instrument logging circuit is the No. 7 cable core. The specific situation is shown in Figure 2.

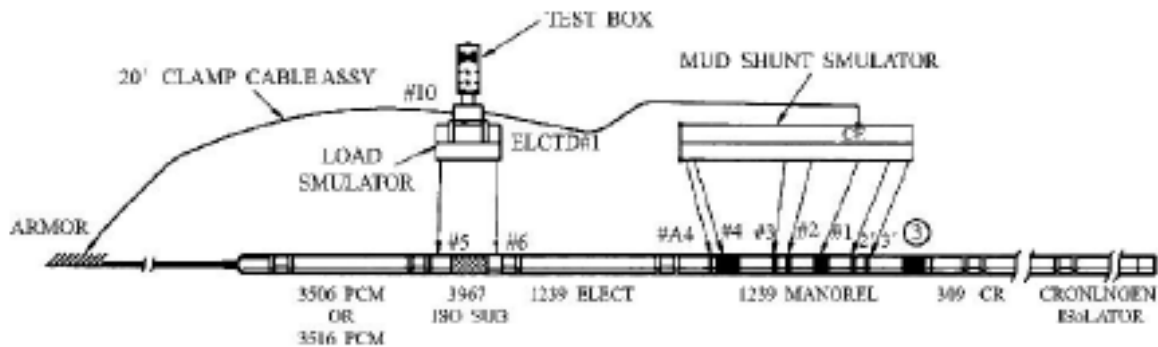

Figure 2. Dual lateral instrument logging machine connection diagram

It is precisely because of the deep lateral structure, long-distance wires are required during the operation. Therefore, the No. 10 cable core and the No. 7 cable core are relatively critical structures. If any line operation is not in place or the resistance value is large, it will affect the basic level of operation which may even cause errors in lateral operation<sup>[4]</sup>. Based on this, the No. 10 cable core and the No. 7 cable core have great influence in the actual application management process.

On the one hand, the abnormality of the No. 10 core will cause damage and handling difficulty of the entire channel, and the damage of the deep-screen circulation is also large, which may cause unusual operation of ES and IS. On the other hand, if the 7th core is abnormal, it will cause a flaw in the voltage measurement circuit, and it should be combined with the ID value for analysis<sup>[5]</sup>.

That is to say, in order to fundamentally improve the judgment of the corresponding data, it is necessary to carry out comprehensive analysis in combination with the reliability flipping process of the scale relay and the contact effect, and comprehensively analyze the overall loop that cannot be checked by the indoor loop circuit<sup>[6]</sup>. It is worth mentioning that the relevant personnel only can avoid the abnormal problem of numerical jump during the logging process, hardly by establishing a

complete loop processing mechanism.

### 3.2 Logging SP

In the process of comprehensive analysis of the lateral corresponding structure, the lateral rubber bridles are all electrode ring structures, which are basically SP rings, but not close to the outer skin of the cable. Lateral and micro lateral combined logging also effectively improves the efficiency of bridle's operation, if the micro lateral reference electrode can be effectively processed, and the rationality improves the micro lateral loop effect<sup>[7]</sup>.

### 3.3 Deep drive board

In the process of coordinating the analysis of the dual-sided instrument logging, the double-sided deep drive board is placed in between U1 and the power amplifier U2 piezoelectric constant current source for processing. However, in the process of pairing the two sides with other instruments, it is often the case the instrument insulation is low, which will cause the current and voltage processing efficiency of the deep side drive board. In the structure of the output current, the ratio of the primary voltage and the resistance can be effectively analyzed<sup>[8]</sup>. For example, UI-2 and UI-3 Zener diodes can be used to manage high voltage and interference, and can avoid U1 burnout. See Figure 3.

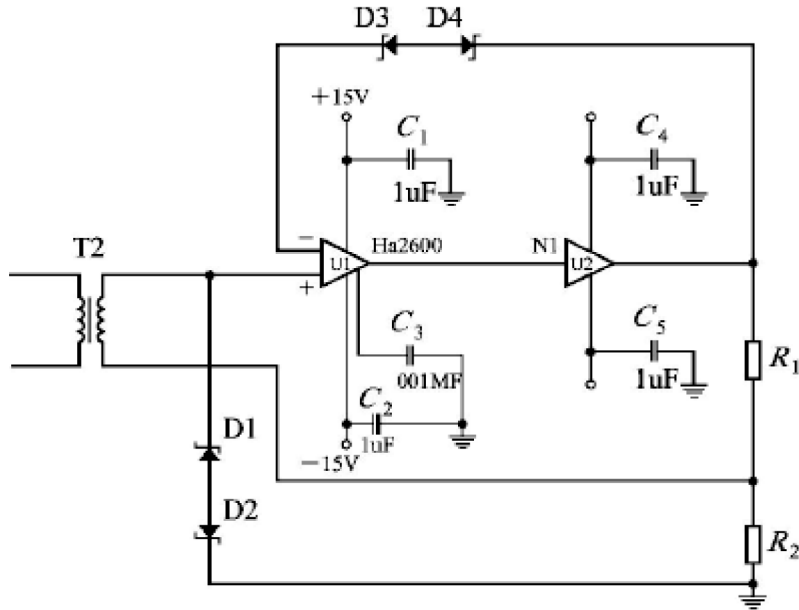

Figure 3. Double-sided deep drive board

### 3.4 Band-pass filter

For dual-sided instrument logging, the deep lateral working frequency itself is 32Hz, and the shallow lateral working frequency is 128Hz. The center of the band-pass filter in the corresponding electronic path is offset, which will comprehensively regulate the oil and gas layer division process<sup>[9]</sup>. That is to say, in the band-pass filter, when the center frequency is shifted, a large

phase shift is generated, resulting in an error in the center frequency offset. It is precisely because of the central frequency of the band-pass filter and the deep lateral instrument and the shallow lateral instrument, so as to establish a complete maintenance and adjustment process to effectively increase the center frequency<sup>[10]</sup>. If the deep side analysis mode is the key, then the deep side fast follow filter circuit is shown in Figure 4.

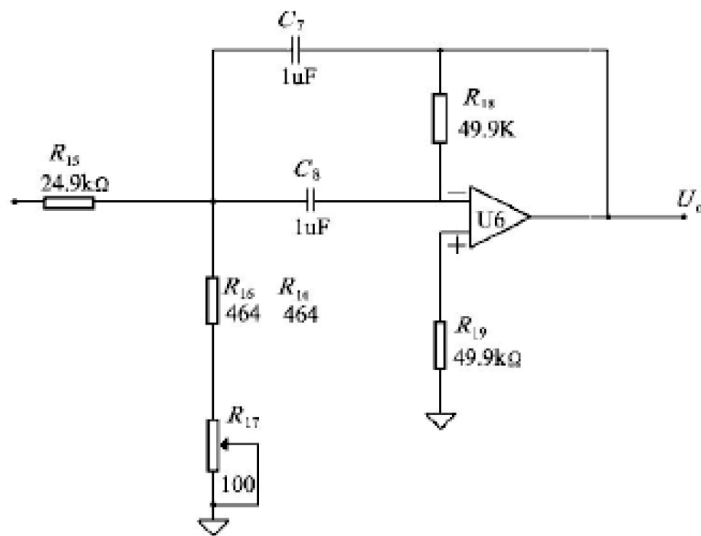

Figure 4. Schematic diagram of the deep lateral band-pass filter

## 4 Double lateral instrument logging quality optimization measures

In order to effectively improve the operation quality of dual-sided instrument logging, it is necessary

to inclusively analyze the specific conditions and operational efficiency, inclusively integrate management and control expectations, and ensure inclusive analysis of the corresponding quality factors.

#### 4.1 Optimizing the lateral shifting power supply

In the application process of lateral shifting power supply, it is necessary to combine the shift voltage level with the bridle voltage for proportional processing, especially in the case of high well depth, because the power supply's own frequency is low, there will be a change at this time. The problem is that the block work is not in place, this requires the relevant technical personnel to perform appropriate voltage adjustment in combination with the actual operation and operation requirements, and raise the voltage to about 180V, thereby compensating for the problem of insufficient power supply for the entire structure.

In addition, if the deep side-to-screen power supply circuit has a problem of poor conduction and operation, it is necessary to actively integrate specific management points to ensure that the current value can be maintained. However, the difference between the resistivity and the low resistance is small, and it can be effective. The parameters are expanded to control the depth, especially during the downhole process, which can effectively maintain the righting efficiency<sup>[6]</sup>.

#### 4.2 Integrated indoor scale

In the dual-side instrument logging management work, relevant personnel should actively integrate specific problems and specific control mechanisms to ensure that the lateral logging determination process can be analyzed, and the simulation probe application efficiency is integrated to ensure that the lateral direction can be determined by engineering values. The resistivity of the logging provides protection for the management and application of engineering values.

In general, the laboratory calibration engineering numerical parameters should be controlled within a certain range. The specific parameters are as follows: 1) mode is LLD, engineering low value (CAL) is 9.5, engineering high value (ZERO) is 9500; 2) mode is LLS, engineering low value (CAL) is 15.9, engineering high value (ZERO) is 15900; 3) mode is LLD, Ed is 3950mV-4250mV, Id is 21mV-26mV, Es is 290mV-350mV, Is is 1600mV-1900mV; Mode is LLS, Ed is 3700mV-4050mV, Id is 11-16mV, Es is 275mV-325mV, and Is is 950mV-1150mV. With the 5700 ground test system, the scale analysis, voltage analysis, current analysis, etc. are comprehensively determined. The specific parameters are as follows: 1) CAL, Ed is 322, Id is 1737, Es is 305, Is is 1035; 2) ZERO, Ed is 3984, Id is 22, Es is 3785, and Is is 12.

According to the corresponding relationship of the parameters, the information can be analyzed, and the linear relationship between the resistivity and the true resistivity of the formation is excellently determined. Effectively establishing a complete data correspondence analysis mode can improve the operating efficiency of the equipment.

#### 4.3 Improve comprehensive information

In the comprehensive analysis of the dual lateral logging, it is necessary to combine the logging circuit and the natural potential to coordinate the information, integrate the management points, and combine the band-pass filter to solve the problem and effectively analyze the control efficiency. Technicians should improve the processing of logging circuits, deep drive boards, band-pass filters and other projects to improve the efficiency of integrated information management.

On the one hand, it is necessary to comprehensively determine the indoor analog scale, effectively analyze the working range of the sampled value of the voltage and current parameters, determine the corresponding application process according to the rationality, and maintain the efficiency of the operation, and integrate the effect of the management and control mode. Optimize the regulatory process of the project.

On the other hand, in the field logging process, the voltage and current logging range should be supervised, and the feasibility analysis mechanism should be fully integrated to effectively improve the basic value of the management mode. The indoor analog scale and field test can be used to verify the accuracy of the corresponding method and improve management. The comprehensive value of the model improves the operating efficiency of the dual lateral logging.

### 5 Conclusions

In summary, in the application of dual-side logging application management, the technical personnel should carry out specific analysis in combination with specific problems, improve the basic efficiency of the test project, ensure the application of the control structure, and rationally maintain the comprehensive efficiency of the control project, and improve the integration. The value of the application also guarantees the field test verification analysis.

### References

- [1] Xue MX. Improvement of the electrode system of SDZ-

- 3060C dual lateral logging tool[J]. *Offshore Oil*, 2017, 37(3):49-51.
- [2] He GL. Analysis of Factors Affecting Shape and Amplitude of Double Lateral Logging Curves[J]. *PetroChina Chemical Industry Standards and Quality*, 2019, 39(2):116-7.
- [3] Wang XB, Zhao GP, Yin LS, et al. Typical Fault Analysis and Processing of HH2530 Double Lateral Instrument[J]. *PetroChina Chemical Industry Standards and Quality*, 2016, 36(18):89-91.
- [4] Liu YB. Research on the anomaly of natural potential curve of SDZ-30B0 induction logging[J]. *Offshore Oil*, 2017, 37(2):66-8.
- [5] Tian YZ. Analysis of Circuit Faults of SDZ-30B0 Double Induction-Eight Lateral Logging Tool[J]. *Neijiang Technology*, 2018, 39(8):75, 89.
- [6] Chen HT. Analysis of Influencing Factors of Horizontal Lateral Logging Response and Its Application in Interpretation[J]. *Foreign Well Logging Technology*, 2017(38):40.
- [7] Zhang C, Liu GQ. Analysis of influencing factors of dual lateral logging based on finite element method of circumferential magnetic field[J]. *Chinese Journal of Geophysics*, 2017, 60(1):441-50.
- [8] Ni XW, Xu SH. Numerical Simulation of Forward Response of Double Lateral Logging in Shale Gas Layer[J]. *Energy and Environmental Protection*, 2017(3).
- [9] Ma L. Research on the characteristics of double lateral logging curves in high slope and horizontal wells[J]. *Inner Mongolia Petrochemical*, 2018(1):96-8.
- [10] Liang XC, Zhao LM, Zhang H, et al. Application of software synthesis focusing on ultra-thin layer double lateral logging instrument[J]. *Computer Applications in Petroleum Industry*, 2018, 97(01):11-4.