

A Simulation Research on the Grid-Connected Control Technology of Single-Phase Inverters Based on MATLAB

Jinjie Chen*

School of Electrical and Automation Engineering, Nanjing Normal University, Nanjing 210023, China

*Corresponding author: Jinjie Chen, 21190420@njnu.edu.cn

Copyright: © 2022 Author(s). This is an open-access article distributed under the terms of the Creative Commons Attribution License (CC BY 4.0), permitting distribution and reproduction in any medium, provided the original work is cited.

Abstract: This paper primarily discusses the main circuit of single-phase inverter circuits. It begins by introducing the research context and the significance of the subject, then discusses the topology of grid-connected single-phase inverter circuits, continues by discussing the control strategy for grid-connected single-phase inverter circuits, realizes a sinusoidal pulse width modulation (SPWM) signal generation circuit and an inverse control algorithm program, and finally ensures good output waveform and fast dynamic response. In view of the hysteresis feature of the grid voltage's synchronous signal sampling circuit, the acquisition function in digital signal processing (DSP) control chips is applied, and the reasons for the hysteresis phenomenon are thoroughly investigated. The reliability of the SPWM control algorithm is revealed through the results.

Keywords: Solar energy; Photovoltaic power generation; Grid-connected inverter circuit; MATLAB simulation

Online publication: July 27, 2022

1. Research background

In the 21st century, the global energy crisis is escalating. According to a report by the World Energy Congress, the world's explored energy reserves have been used by mankind for no more than 200 years. Therefore, it is urgent to develop new energy ^[1]. As the largest developing country in the world, China ranks first in energy consumption growth. In 2017, China's total energy consumption was 24.6 billion tons of standard coal, an increase of 9.3% over previous years ^[2]. Due to technological barriers, China's energy development is occurring at a sluggish rate that is far slower than the global average, hastening the country's imminent new energy collapse ^[3]. According to a report presented by China Electric Power Research Institute, the energy supply-demand gap between 2010 and 2020 is 6.4% and 10.7% ^[4]. Therefore, China's primary strategy for keeping pace with global energy development is the growth of renewable energy. The development of solar energy addresses China's fundamental national needs. Hence, China's future energy supply may rely heavily on solar photovoltaic energy generation ^[5]. The grid connection technology is crucial for photovoltaic inverters. ¹²³⁴⁵

2. Topology and control strategy of grid-connected single-phase inverter circuit

2.1. Topology of grid-connected inverter circuit

An inverter circuit requires a simple topology to reduce energy loss in the transmission process ^[6]. In regard to output, it is important to consider whether the input and output terminals meet certain requirements, such

as THD (total harmonic distortion) $< 5\%$ and power factor 1 [7]. Inverter circuits can be divided into isolated inverter circuits and non-isolated inverter circuits, in which an isolated inverter circuit can be either a high-frequency isolation type or a power frequency isolation type, while a non-isolated inverter circuit can be either single-stage or two-stage [8]. [6,78]

- (1) Power frequency isolation transformers usually adopt the DC/AC mode, as exemplified by the power frequency isolation transformer circuit diagram in **Figure 1A**. This mode will not only effectively isolate the power grid, but also filter the DC component of the output waveform of the inverter circuit, which can reduce pollution to the power network [9]. [9]
- (2) As shown in **Figure 1B**, single-phase transformers only use one-level DC/AC to be directly connected to the power grid, which can improve the efficiency of the inverter circuit.

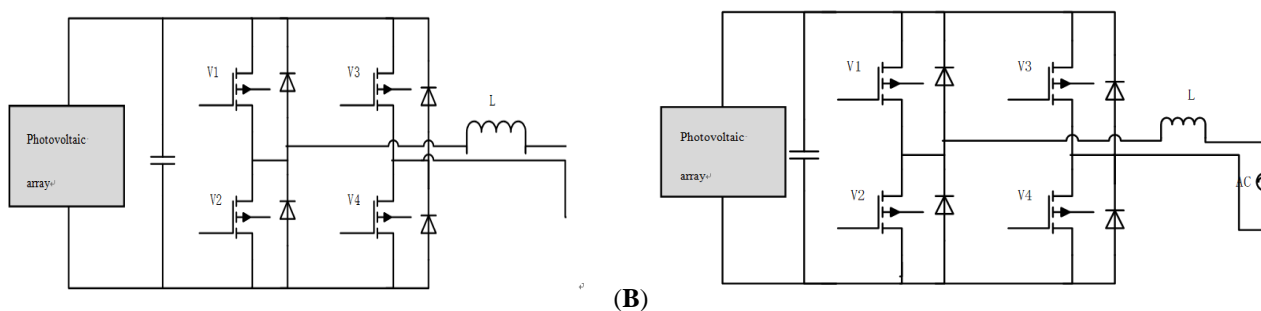

Figure 1. Topology of grid-connected inverter circuit; (A) Power frequency isolation transformer; (B) Single-phase transformer

2.2. Working principle of grid-connected inverter circuit

Using voltage input to control current output, a single-phase inverter circuit can be designed [10]. This paper selects a single-phase full bridge inverter circuit. The circuit structure is shown in **Figure 2**. Filter inductance is added to the final output portion of the inverter circuit to reduce current burr, and voltage is transmitted to the power grid through the power frequency isolation transformer. As shown in **Figure 2**, the input voltage on the DC side is recorded as U_d , and the smoothing capacitor on the DC side is recorded as C . It also has energy storage function. AC is the output voltage of the whole inverter circuit, and L is the filter inductance. Using high-frequency SPWM control, the two pairs of IGBT tubes are turned off alternately, creating an equivalent AC voltage, so as to repeat the equivalent AC voltage and filter L to form sinusoidal AC signals at the output. At the same time, the reactive power supply feedback channel is attached to the power side, and each arm of the inverter bridge is connected with the feedback diode in parallel [11]. [10]

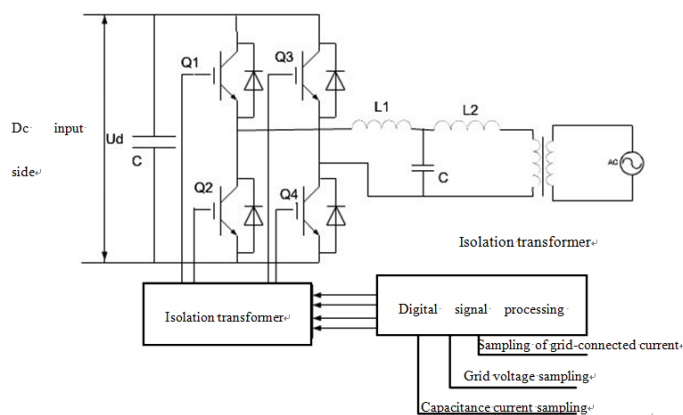

Figure 2. Topology of the main circuit

3. Research and implementation of the control strategy for grid-connected single-phase inverters

3.1. Digital SPWM modulation and SPWM signal generation circuit

Most inverse modulations are SPWM waves generated by DSP chips [12]. This paper will use DSP to calculate the SPWM-wave-driven inverter circuit [13]. The TMS320LF2407 has EVA and EVB management modules, which can control the output of 16 PWM signals. In this design, only four event management modules (EVA) are used, which are recorded as PWM1~PWM4; other EVAs can be used as standby. PWM is a very effective technology for DSP to control analog circuit. Based on the corresponding load change, the preload of the base or the gate of MOS tube can be set to realize the change of the line time of the transistor or MOS tube, so as to realize output change [14].¹¹¹²

3.2. Generation principle of bipolar SPWM

In order to generate an ideal SPWM wave, it is necessary to select the appropriate modulation wave and carrier wave. This paper selects the sine wave and triangular wave as the modulation wave and carrier wave, respectively [15]. The modulated wave is recorded as u_s ; its frequency and amplitude are set as f_s and U_{sm} , respectively. The carrier wave, as a triangular wave, is recorded as u_c ; its amplitude and frequency are specified as U_{cm} and f_c , respectively. The carrier ratio is the ratio of the fundamental triangular wave f_c to the sinusoidal modulation wave f_s ; that is, $p = f_c/f_s$. The modulation depth is marked as m , which is defined as the ratio of the amplitude of the modulation signal to the triangular wave signal, where $m = U_{sm}/U_{cm}$. The change of modulation depth m will affect the fundamental amplitude of the SPWM inverter's output voltage [16]. When the base frequency and modulation depth of the output voltage are much lower than the carrier frequency, the amplitude of the base voltage U_1 and U_{1m} satisfies the following relationship:

$$U_{1m} = mU_d$$

4. MATLAB simulation of the inverter circuit

4.1. Inverter simulation

In the simulation environment, a simulation circuit model is created in MATLAB/Simulink. As shown in **Figure 3**, the bridge arms of two general bridge modules are selected to form a single-phase full bridge circuit. The insulated-gate bipolar transistor (IGBT) of the anti-parallel diode is selected for the switchgear; then, the DC voltage module is set to 45 volts; the resistance and inductance loads are set to 1Ω and 5 mH, respectively [17]. A PWM generator is used to process the bipolar SPWM wave. The modulation depth $m = 0.8$, the output fundamental frequency is 50Hz, and the carrier frequency is set to 60 times of the fundamental frequency [18]. The simulation time is set to 0.06 seconds, and the sampling time is set to 5.1×10^{-6} seconds. Based on the simulation environment set, the waveforms of output AC voltage and AC current can be obtained, as shown in **Figure 4**. The output current is 50Hz sine wave, and the voltage is bipolar PWM type.

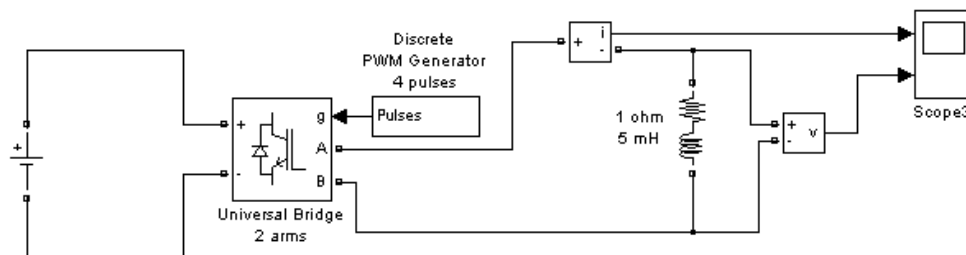

Figure 3. Simulation model of bipolar SPWM single-phase full bridge inverter circuit

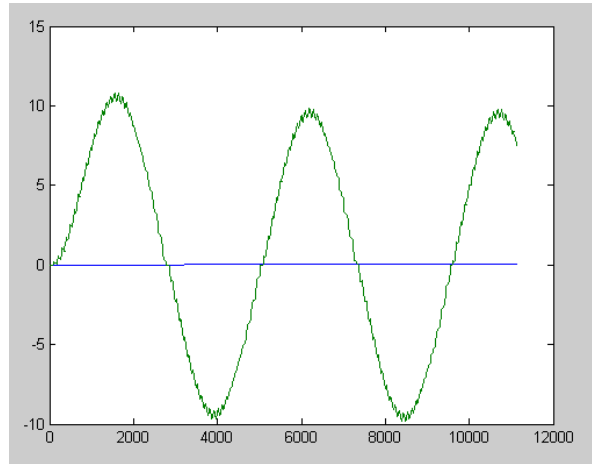

Figure 4. Simulation diagram of the single-phase full bridge inverter model

4.2. Grid-connected inverter circuit simulation

After designing the inverter circuit, the entire inverter circuit model is analyzed and simulated. The simulation model is shown in **Figure 5**. Without any added feedback, the simulation results are shown in **Figure 6**.

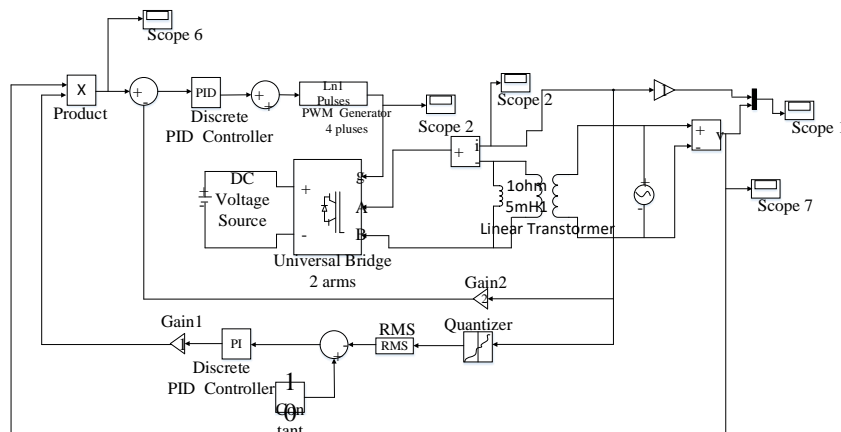

Figure 5. Simulation model of voltage-current double closed-loop feedback control circuit

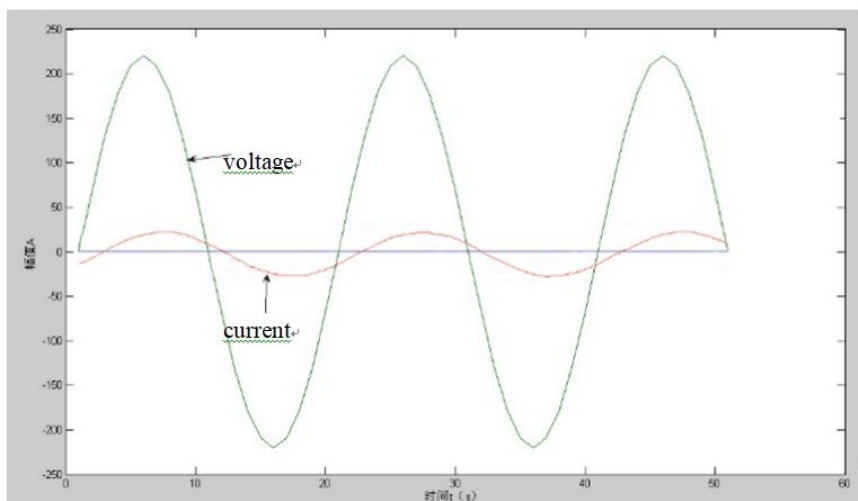

Figure 6. Grid connection simulation diagram without feedback regulation

It can be seen from **Figure 6** that the voltage and current signals are not synchronized. Hence, the power factor may not reach the predetermined value. The reason for this is that the inverter is not regulated by the voltage-current double closed-loop feedback. The grid connection simulation results after feedback regulation are shown in **Figure 7**.

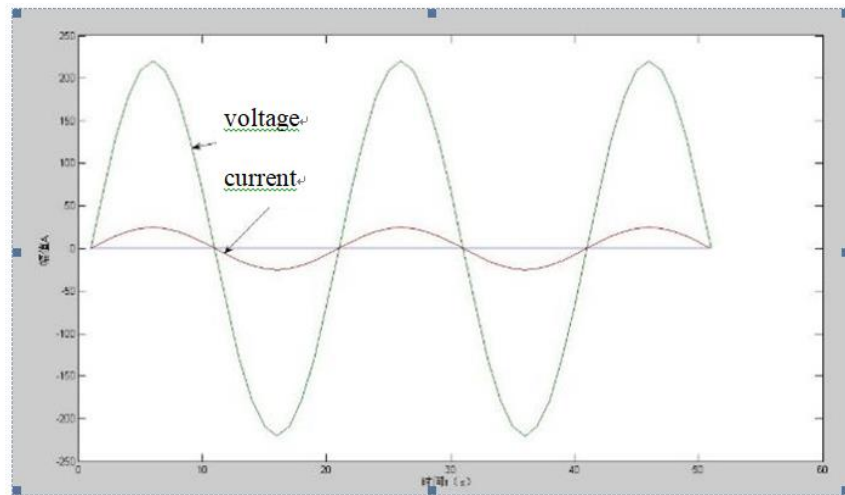

Figure 7. Grid connection simulation diagram with voltage-current double closed-loop feedback regulation

From **Figure 7**, it can be seen that the waveform in **Figure 6** has the same frequency and phase effects as the grid-connected current after the voltage-current double closed-loop feedback. The predetermined power factor can be achieved once the current is connected to the grid. The purpose of the design is realized through the network.

Disclosure statement

The author declares no conflict of interest.

References

- [1] Jiang W, Liu M, Chen Y, et al., 2020, Research on Compound Control of Inverter Based on Fuzzy PI and Repetitive Control. *Electronic Devices*, 43(06): 1273–1277.
- [2] Liu C, Li Z, Lv J, et al., 2020, Three-phase Unbalance Suppression Method of Photovoltaic Inverter Based on Reactive Power Control. *Power System and Clean Energy*, 36(12): 107–114.
- [3] Wu H, Ding X, Qin L, 2020, Current Control Strategy of Single-phase LCL Grid-Connected Inverter Based on DQ Coordinate System. *Guangxi Electric Power*, 43(06): 62–66.
- [4] He J, Zhang D, 2021, Research on VSG Current Suppression Technology of Grid-Connected Inverter During Voltage Sag. *Electrical Measurement & Instrumentation*, 58(04): 24–29.
- [5] Yuan Y, Lv S, 2021, A Control Strategy for Effectively Broadening the Stability Region of Cascaded Photovoltaic Inverters. *High Voltage Technology*, 47(03): 972–982.
- [6] Yang X, Wang M, Sun Y, et al., 2021, Power Balance Control Strategy of Two-Stage Cascaded H-Bridge Grid-Connected Photovoltaic Inverter. *Journal of Electric Power Systems and Automation*, 33(04): 76–83.
- [7] Li D, Chang Y, 2021, Research on Composite Control Strategy of Single-Phase H6 Grid-Connected Inverter. *Telecom Power Technologies*, 38(03): 27–30 + 34.

- [8] Jiang L, Zhao P, Han L, et al., 2021, A Low-Leakage Current Five-Switch Non-Isolated Single-Phase Grid-Connected Photovoltaic Inverter. *Journal of Solar Energy*, 42(08): 177–182.
- [9] Han C, Ding X, Liang L, et al., 2021, Quasi-Proportional Resonance Control of Single-Phase LCL Grid-Connected Inverter. *Journal of Guangxi University (Natural Science Edition)*, 46(04): 973–981.
- [10] Hu B, Ren T, Che X, et al., 2020, Research on Control Technology of Grid-Connected Microgrid Inverter Based on QPCI Control. *Smart Power*, 48(01): 23–27 + 41.
- [11] Yu H, 2018, Research on Grid-Connected Single-Phase Photovoltaic Inverter Control System. *Anhui University of Science and Technology, Anhui*. <http://doi.org/10.7666/d.Y3395594>
- [12] Ran Y, Wang W, Wang Y, 2020, Single-Phase Non-isolated Improved Y-Source Grid-Connected Photovoltaic Inverter. *High Voltage Technology*, 46(03): 1087–1098.
- [13] Gao X, Cao C, Zhou X, 2011, Simulation Analysis of Single-Phase Grid-Connected Inverter Based on One-Week Control. *Electromechanical Engineering*, 28(5): 620–623. <http://doi.org/10.3969/j.issn.1001-4551.2011.05.026>
- [14] Huang C, Zhang Q, Deng Y, et al., 2011, Research on MATLAB Simulation of Single-Phase Photovoltaic Two-Stage Grid-Connected System. *Chinese Journal of Power Sources*, 35(5): 553–555. <http://doi.org/10.3969/j.issn.1002-087X.2011.05.022>
- [15] Niu H, He G, Wu Y, 2020, Design of Active Disturbance Rejection Controller for Photovoltaic Grid-Connected System Based on Discrete Control. *Journal of Henan Institute of Urban Construction*, 29(01): 71–76 + 87.
- [16] Cao T, Xu J, Qi Q, et al., 2012, Control Technology of Single-Phase Grid-Connected Photovoltaic Inverter. *Power Automation Equipment*, 32(5): 133–136. <http://doi.org/10.3969/j.issn.1006-6047.2012.05.025>
- [17] Nie X, 2018, Research on Control Technology of Single-Phase LCL Grid-Connected Photovoltaic Microinverter. *Nanchang University, Jiangxi*.
- [18] Yuan R, 2017, Research on Single-Phase Grid-Connected Inverter Based on Model Predictive Control Technology. *Nanjing University of Aeronautics and Astronautics, Jiangsu*.

Publisher's note

Bio-Byword Scientific Publishing remains neutral with regard to jurisdictional claims in published maps and institutional affiliations.