

Analysis of Smart Grids Incorporating Wind, Solar, and Energy Storage

Zihan Wang*

Nanjing Tech University, School of Electrical Engineering and Control Science, Nanjing 210000, Jiangsu, China

**Author to whom correspondence should be addressed.*

Copyright: © 2026 Author(s). This is an open-access article distributed under the terms of the Creative Commons Attribution License (CC BY 4.0), permitting distribution and reproduction in any medium, provided the original work is cited.

Abstract: To address operational challenges such as reduced grid inertia and intensified power fluctuations caused by high renewable energy penetration, this paper systematically introduces the coordinated optimization and stability control technologies for wind-solar-storage smart grids. A three-tier time-scale (“day-ahead-intraday-real-time”) collaborative optimization framework was established, demonstrating a multi-objective dispatch model integrating electricity markets and frequency regulation auxiliary services to achieve synergistic improvement in economic benefits and renewable energy integration. After that, a hierarchical coordinated control strategy for hybrid energy storage was analyzed, where adaptive filtering algorithms decompose power commands into low-frequency energy components and high-frequency power components, which are respectively responded to by lithium batteries and supercapacitors, enabling organic integration of system-level dispatch and device-level control. Simulation results from a 300MW wind-solar-storage demonstration project in Northwest China show that the proposed strategy can increase the total revenue of combined power plants by approximately 22% while reducing curtailment rates by 8%. In terms of power fluctuation mitigation, the grid-connected power fluctuation rate is controlled within $\pm 2\%$, and frequency deviations are maintained within the safe range of ± 0.1 Hz. The research findings provide technical support for the safe and stable operation of high-renewable grids and hold significant engineering application value.

Keywords: Wind and solar energy storage system; Smart grid; Hybrid energy storage; Model establishment

Online publication: April 3, 2026

1. Introduction

The global energy structure is undergoing a profound transformation with low-carbon and clean energy as its core, and the large-scale development of renewable energy, such as wind power and photovoltaics, has become a key path to building a new type of power system. However, wind power and photovoltaic power generation have intermittency, volatility, and randomness, which pose severe challenges to real-time power balance in the power system. The issues of system frequency and voltage stability are becoming increasingly prominent, restricting the efficient consumption of new energy and the safe and stable operation of the power grid.

To solve the above problems, the combination of energy storage systems and wind and solar power generation to form a smart grid containing wind and solar energy storage is considered an effective solution to achieve smooth energy output and improve system flexibility. Energy storage can provide fast power regulation and energy buffering, compensating for insufficient wind and solar power output on a time scale. In-depth research on the collaborative optimization and stable control strategy of wind solar energy storage smart grid not only helps to develop multi-energy complementary system planning methods, but also has important practical significance for ensuring power supply security and promoting energy structure transformation^[1,2].

In terms of collaborative optimization operation of wind, solar, and energy storage, existing research mainly focuses on building mathematical models around the goals of optimal economic efficiency or minimizing wind and solar power curtailment. Random optimization, robust optimization, and model predictive control methods are used to address the uncertainty of wind, solar, and energy output. Further refinement and coordination across multiple time scales, as well as collaborative optimization of the entire lifecycle of hybrid energy storage, are still needed^[3].

In terms of power grid stability and control technology, energy storage systems have been widely studied for providing services such as virtual inertia, primary frequency regulation, and damping oscillation. Hybrid energy storage systems often adopt filtering-based power allocation strategies, but current research is mostly focused on device-level local control. The integration of system-level scheduling and device-level control is still insufficient, and a unified control framework that meets energy management and stability control requirements has not yet been formed.

This article conducts a systematic study on the safe, efficient, and stable operation of smart grids containing wind and solar energy storage. Using the “day-ahead day real-time” multi-time scale collaborative optimization and hierarchical coordination control method, the problem of safe, efficient, and stable operation of smart grids containing wind and solar energy storage is introduced. A series of achievements have been made, including refined modeling of wind and solar energy storage, construction of a multi-scale optimization scheduling framework, design of a grid stability hierarchical control strategy, and technical and economic evaluation. The aim is to improve the stability and operational efficiency of high-proportion new energy grids and promote the consumption of new energy.

2. Modeling and characteristics analysis of smart grid system with wind and solar energy storage

2.1. Mathematical model and output characteristics analysis of wind power generation system

The output power of a wind turbine is mainly determined by the wind speed, and its mathematical model can be expressed in the form of a piecewise function. When the wind speed is lower than the cutting in wind speed or higher than the cutting out wind speed, the fan output is zero; When the wind speed is between the cut in wind speed and the rated wind speed, the output is approximately proportional to the third power of the wind speed. When the wind speed reaches the rated wind speed, the output is maintained at the rated power. Specific reference can be made to **Formula 1**, which has clear physical meaning, strong engineering practicality, simplifies the calculation of complex aerodynamic characteristics, and can be directly used for power prediction and collaborative optimization of wind solar energy storage systems, providing basic data support for multi-time scale scheduling from day-ahead to day ahead.

$$P_{ot} = \begin{cases} 0 \\ \frac{1}{2} C_p \rho \pi R^3 v^3 \\ P_r \end{cases} \begin{cases} v < v_{ci} \text{ or } v > v_{\infty} \\ v_{ci} \leq v < v_r \\ v_r \leq v \leq v_{\infty} \end{cases} \quad (1)$$

Among them, P_{ot} is the output power of the wind turbine, P_r is the rated power, C_p is the wind energy utilization coefficient, v_{ci} is the cut in wind speed, v_r is the rated wind speed, v_{∞} is the cut out wind speed, R is the blade radius, and ρ is the air density, which are related to environmental factors such as altitude, temperature, and humidity.

2.2. Mathematical model and output characteristics analysis of photovoltaic power generation system

The output power of photovoltaic cells is directly related to solar irradiance and environmental temperature. Its simplified engineering mathematical model can be expressed as:

$$P_{pv} = P_{stc} \cdot \frac{G}{G_{stc}} \cdot [1 + k \cdot (T_c - T_{stc})] \quad (2)$$

Among them, P_{stc} is the maximum power under standard testing conditions, G is the actual irradiance, k is the power temperature coefficient, and T_c is the operating temperature of the solar panel. The photovoltaic output exhibits obvious diurnal and seasonal periodicity and is easily affected by weather changes, with intermittency.

Although there is a certain degree of overlap between its peak output and daytime load, the minute-level power drop caused by cloud cover still needs to be addressed^[4].

2.3. Modeling and characteristics analysis of hybrid energy storage systems

The hybrid energy storage system achieves decoupling of power responsibility and energy responsibility through complementary characteristics, which can efficiently cope with long-term energy translation and second/millisecond level power shocks, while improving overall system performance and extending battery life. The core principle is to organically combine energy storage units with different charging and discharging characteristics (such as lithium batteries, supercapacitors, flywheel energy storage, etc.), and achieve complementary advantages through reasonable control strategies: lithium batteries, with their high energy density characteristics, are responsible for long-term energy storage and release tasks. To cope with the difference in daytime and nighttime loads, and to mitigate the hourly energy imbalance caused by fluctuations in renewable energy output such as wind and solar power; Supercapacitors or flywheel energy storage, with their extremely fast response speed (in milliseconds), high power density, and long cycle life, are specifically designed to cope with rapid dynamic processes such as instantaneous power surges, voltage flicker, frequency fluctuations, etc. in the power grid, such as transient recovery after short-circuit faults and power shortages caused by sudden load changes. This collaborative working mode of “slow charging and slow discharging” and “fast charging and fast discharging” not only achieves the decoupling of power regulation and energy storage functions, avoiding the performance bottleneck of a single energy storage technology when dealing with multi time scale demands, but also significantly reduces the charging and discharging depth and cycle times of lithium batteries, thereby effectively extending their service life. In terms of modeling, it is usually necessary to establish mathematical models for each sub energy storage unit separately (such as the equivalent circuit model of lithium batteries, the RC model of supercapacitors, etc.), and then use multivariable control algorithms (such as fuzzy control, neural network control, model predictive control, etc.) to achieve power allocation and coordinated control between each unit, to ensure

that the system can operate stably and efficiently under various working conditions, ultimately achieving the goal of improving the stability, economy, and reliability of the entire power system ^[5].

3. Collaborative optimization of wind solar storage systems considering multiple time scales

3.1. Collaborative operation framework for wind solar storage system

This article has a three-layer collaborative operation framework, with a demonstration system in a province in northwest China as the application background. The system includes a 300MW wind and solar installed capacity and a 40MW/80MWh lithium battery + 5MW/0.5MWh supercapacitor hybrid energy storage. The day ahead dispatching layer formulates unit combination and power plan based on short-term forecast and time of use electricity price with a 24-hour cycle; The intraday rolling layer uses several hours as a window and utilizes ultra short term forecast data to adjust the daily plan at intervals of 5–15 minutes; The real-time adjustment layer is controlled by hybrid energy storage at the second/minute scale to suppress and stabilize fluctuations. Three layers form a closed-loop optimization system through power commands and state feedback ^[6,7].

3.2. Days ago optimized scheduling model

3.2.1. Objective function

The goal is to minimize the total operating cost or maximize the total revenue of the system within the scheduling period. In the electricity market environment, the objective function can be adjusted to:

$$\max \sum_{t=1}^T [\lambda_t^{energy} \cdot P_{grid,t} + \lambda_t^{FR} \cdot P_{FR,t} - C_{fu}] \quad (3)$$

Among them, max represents the goal of maximizing the function value. For the priority goal of maximizing total revenue, T is the total number of time periods in the scheduling cycle, t represents the t -th time period of scheduling, λ_t^{energy} is the electricity market price in the t -th time period, $P_{grid,t}$ is the electricity power sold by the wind and solar storage system to the grid in the t -th time period, λ_t^{FR} is the electricity price of the frequency modulation auxiliary service capacity provided by the system in the t -th time period, $P_{FR,t}$ is the frequency modulation auxiliary service capacity provided by the system in the t -th time period, C_{fu} is the total operating cost of the system in the t -th time period, including conventional unit fuel cost, start stop cost, wind and solar storage and maintenance cost, wind and solar curtailment penalty cost, etc.

Simply put, the core of the formula is the total revenue minus the total The goal is to maximize the difference in operating costs.

3.2.2. Constraints

The model must meet the following constraints: system power balance constraint; Constraints on the upper and lower limits of output, ramp rate, and minimum start stop time for conventional units; Upper and lower limit constraints on the output of wind and solar power units; Energy storage system charging and discharging power, SOC upper and lower limits, and initial and final state constraints. In addition, it is necessary to consider the capacity constraints reserved for the frequency modulation market; that is, the available power of energy storage systems (especially supercapacitors) needs to meet both energy optimization and backup capacity requirements.

3.2.3. Model solution and market strategy application

This model is a typical mixed integer linear/nonlinear programming problem that can be solved using commercial solvers such as CPLEX/Gurobi or improved particle swarm optimization algorithms. Based on this model, the joint power station can formulate market strategies. In the daily electricity market, based on wind and solar power output prediction and electricity price prediction, optimize the bidding electricity quantity and price for each time period of the next day. The energy storage system implements an arbitrage strategy of “low storage, high incidence”, while charging during periods of high wind and solar power generation and low electricity prices to reduce power abandonment. At the same time, evaluate and declare the FM capacity that can be provided the next day, and participate in the FM auxiliary service market.

3.3. Daily rolling optimization and real-time adjustment

The intraday rolling optimization adopts a model predictive control framework. At the beginning of each rolling cycle, taking the current system state (such as energy storage SOC) as the initial value, based on the latest ultra short term wind and solar power output, load, and possible real-time electricity price data, solve a finite time domain optimization problem, finely adjust the daily plan, and issue the first time period instruction of the optimal solution sequence for execution. The real-time adjustment layer relies on local measurements. By calculating the deviation between the actual output of wind and solar power and the planned value, or monitoring the frequency/voltage deviation of the grid connection point, an adaptive filtering algorithm (such as wavelet packet decomposition) is used to decompose the total power command that needs to be smoothed into low-frequency and high-frequency components. In the case system, the lithium battery is responsible for responding to low-frequency energy components and executing continuous charging and discharging to track the plan; Supercapacitors are responsible for absorbing high-frequency power components, smoothing out second-level fluctuations, and quickly responding to frequency modulation commands. This division of labor not only smooths the grid-connected power but also creates conditions for providing high-quality frequency regulation services at the same time ^[8,9].

4. Hybrid energy storage control technology

4.1. Analysis of stability issues in wind solar energy storage grid

The stability problems caused by the high proportion of new energy grid connection mainly include three types: frequency stability problems, which originate from the decrease of system synchronization inertia and the large frequency change rate under power disturbances. Voltage stability issues arise from insufficient reactive power support capacity and active power fluctuations. The oscillation problem may be caused by the interaction between power electronic devices, leading to wideband oscillations. In the actual operation of a high proportion of new energy demonstration zones in northwest China, frequency stability issues and voltage fluctuations caused by rapid fluctuations in wind and solar power are particularly prominent.

4.2. Design of hierarchical coordination control strategy

The hierarchical coordinated control strategy designed in this article aims to achieve the coordinated unity of energy management (tracking plan, arbitrage) and stable services (frequency regulation, voltage stabilization). This strategy includes receiving power plans and frequency regulation capacity requirements from the intraday rolling optimization layer described above, which belongs to the system-level optimization instruction layer. At the same time, the local controller generates power compensation signals for stable control based on the frequency deviation

or voltage deviation of the grid connection point, which belongs to the device-level fast-response layer. The final power allocation layer decomposes the total power command through adaptive filtering (such as wavelet packet decomposition, high-pass/low-pass filtering). Low-frequency and large time constant components are allocated to lithium batteries, allowing them to perform energy scheduling tasks while also balancing slow frequency regulation; The high-frequency and small time constant components are allocated to supercapacitors to focus on suppressing power oscillations and providing fast frequency/voltage support ^[10,11].

4.3. Simulation analysis and control effect verification

4.3.1. Scenario 1 (Power fluctuation stabilization and market plan tracking)

Simulate severe fluctuations in wind and solar power output in the simulated case area. The simulation results show that the hierarchical coordinated control strategy proposed in this paper can significantly smooth the grid-connected power, stabilize its volatility within the allowable range, and effectively ensure its execution of bidding plans in the electricity market. As shown in **Figure 1**, the supercapacitor effectively absorbs power spikes, reduces the number and amplitude of battery actions, prolongs battery life, and lowers the overall lifecycle cost.

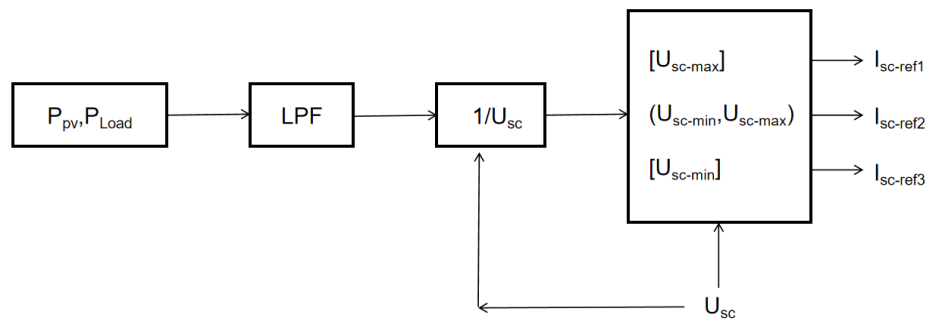

Figure 1. Schematic diagram of supercapacitor control (original).

4.3.2. Scenario 2 (Transient frequency support and auxiliary service benefits)

Simulate the disconnection of large capacity units in the system due to faults. As shown in **Figure 1**, the simulation results clearly demonstrate that the hybrid energy storage system with virtual synchronous machine control can instantly release active power, significantly improve the frequency dynamic response characteristics of the system, reduce the frequency minimum point and steady-state deviation, and prove its strong inertia and primary frequency modulation support capability. This fast and accurate response characteristic is precisely the core advantage of obtaining high-performance indicators (such as a high K-value) and high compensation in the FM auxiliary service market.

4.3.3. Comprehensive benefit analysis

Through a typical daily operation simulation of the case system, it is shown that using the collaborative optimization operation and control strategy proposed in this article, the joint power station not only reduces the wind and solar power curtailment rate by about 8% through power smoothing and plan tracking, but also increases the total revenue by about 22% compared to independent operation of wind, solar, and storage through “low storage and high incidence” and providing high-quality frequency regulation services. This fully validates the comprehensive advantages of the proposed technology in improving system stability, economy, and promoting

the consumption of new energy. For example, in the wind solar energy storage joint demonstration project in the northwest region, after the successful application of this technology, the output fluctuations of local wind farms and photovoltaic power stations were effectively suppressed, and the power grid dispatch department could more accurately track the new energy generation plan. The phenomenon of wind and solar power abandonment was significantly reduced, and the wind and photovoltaic power output that was originally limited due to excessive fluctuations was fully utilized.

Concurrently, the energy storage system releases electricity during peak usage periods, participates in grid frequency regulation, and responds quickly to small frequency fluctuations, providing stable active power support. Its frequency regulation performance indicators have reached the leading level in China, thus obtaining additional frequency regulation benefits from the power grid company. The project achieved efficient consumption of new energy while participating in the auxiliary service market and optimizing the output curve, which increased the overall revenue of the joint power station by nearly 25% compared to traditional models, confirming the significant effectiveness of collaborative optimization strategies in practical applications ^[12,13].

5. Conclusion

This article focuses on the coordinated operation and stable control of smart grids containing wind and solar energy storage. The main achievements include the introduction of a collaborative optimization framework for day-ahead and real-time multi time scales in the integrated electricity market, as well as an optimization model that comprehensively considers energy and frequency regulation services. The system's economy has been significantly improved, and the consumption of new energy has been effectively promoted. At the same time, by discussing the hybrid energy storage hierarchical coordinated control strategy, power adaptive allocation is achieved, integrating energy scheduling with fast and stable control, significantly smoothing power fluctuations, and enhancing grid frequency stability. Actual case simulation verification shows that this strategy achieves a comprehensive benefit of increasing total revenue by 22% and reducing wind and solar power curtailment rates by 8% while ensuring safe operation, fully demonstrating its technological and economic superiority. Future research will focus on optimizing bidding and risk strategies under multi market coupling, deepening the modeling of the entire lifecycle of long-term energy storage, strengthening the application of AI in ultra short term forecasting and decision-making, and expanding multi-unit cluster collaborative control to build a more intelligent and economical power system, enhance market adaptability, promote the consumption of new energy, and promote grid security and sustainable development.

Disclosure statement

The author declares no conflict of interest.

References

- [1] Alharbi A, 2025, Intelligent Particle Filtering State Observer for Stability Assessment in Solar-Wind Penetrated Microgrids. *Scientific Reports*, 15(1): 44350.
- [2] Hu Z, 2025, Analysis and Research on the Architecture and Operational Characteristics of Wind-Solar-Storage Systems. *Science, Technology and Innovation*, 2025(23): 190–192.

- [3] Zhang H, Huang H, Xu J, et al., 2026, Research on the Coordination Between Renewable Energy Development and Territorial Spatial Planning. *Hydropower Generation*, 1–6.
- [4] Wei T, Zhou H, Zhang Y, et al., 2025, Optimization of Capacity Configuration for Rail Transit Wind-Solar-Storage Systems Based on Improved K-Means Algorithm. *Power Capacitors & Reactive Compensation*, 46(5): 28–36.
- [5] Zhang Y, Liu X, Zhang Z, et al., 2025, Research on Optimization and Scheduling of Wind Solar Storage Microgrid for New Energy Consumption. *Northeast Electric Power Technology*, 46(8): 9–14.
- [6] Qiu S, 2025, Multi-Objective Capacity Coordinated Optimization of Dual Energy Storage Combined Power Generation System Considering Wind and Solar Uncertainty. *Journal of Shandong Electric Power College*, 28(3): 38–44.
- [7] Jiang E, Fang C, Wang Y, et al., 2025, Multi-Agent Cluster Control of Voltage in Wind-Photovoltaic-Storage Integrated Distribution Networks. *Electrical Engineering*, 107(9): 1–14.
- [8] Ding Z, Bu W, Xu Y, et al., 2025, Artificial Intelligence on Power Flow Stability Control of High-Penetration Wind-Solar-ES (Energy Storage) Distribution Grid Network. *International Journal of Pattern Recognition and Artificial Intelligence*, 39(5).
- [9] Zhang C, Jiang W, Luo Y, et al., 2025, Multi Data Center Microgrid and Shared Energy Storage Coordinated Optimization Operation Considering Wind and Solar Uncertainty. *Power System Protection and Control*, 53(4): 72–84.
- [10] Cui S, Tan S, Cai H, et al., 2024, Hierarchical Coordinated Control Strategy for Islanded Microgrids Based on Fuzzy Compensation. *Hydroelectric Energy Science*, 42(10): 206–210.
- [11] Wang Y, 2024, Multi Microgrid Collaborative Optimization Operation Strategy Considering Wind and Solar Uncertainty and Equipment Operating Conditions, thesis, Northeast Electric Power University.
- [12] Zhang Y, Gao Y, 2023, Real-Time Electricity Pricing Strategy for Smart Grid Considering Wind and Solar Uncertainty Based on ADMM-GBS. *Distributed Energy*, 8(6): 27–35.
- [13] Zhao P, 2023, Research on Hierarchical Control Strategy for Distributed Photovoltaic Distribution Network, thesis, Northeast Agricultural University.

Publisher's note

Bio-Byword Scientific Publishing remains neutral with regard to jurisdictional claims in published maps and institutional affiliations.