

# Ideological and Political Teaching Case Design and Research Based on the Course Simulation Electronic Technology Experiment

Meiyi Chen\*, Wei Yang, Xin Hao, Shunyu Long, Pengfei Zhong

College of Marine Information Engineering, Hainan Tropical Ocean University, Sanya 572022, Hainan Province, China

\*Corresponding author: Meiyi Chen, chenmeiyi25@hntou.edu.cn

**Copyright:** © 2023 Author(s). This is an open-access article distributed under the terms of the Creative Commons Attribution License (CC BY 4.0), permitting distribution and reproduction in any medium, provided the original work is cited.

**Abstract:** As critical measures to educate and cultivate people's morality, "Ideology and Politics of Course" has gradually become the focus in actual undergraduate education research in universities. Targeting the single ideological and political education mode and students' lack of interest in experimental courses, this paper, through various links, including pre-class preview, in-class teaching, and after-class data analysis, takes the common emitter single tube amplifier experiment as an example to organically integrate the excavated ideological and political elements with practical operation and carry out teaching case design and practice; realize the improvement of students' learning initiative and problem-analysis ability; and achieve the purpose of cultivating people throughout the whole process and in a comprehensive direction.

**Keywords:** Ideology and politics; Simulation electronic technology experiment; Teaching design

**Online publication:** February 24, 2023

## 1. Introduction

The growth and development of college students, as the main driving force of realizing the Chinese dream and the core of building socialism with Chinese characteristics, have always been the top priority of the party and the state. As a result of the increasing exchanges between China and various countries in the world, the local education environment, especially the mode of moral education, is now exposed to various problems. From the perspective of educating people, college students are in a critical period of mental maturity; thus, they are extremely malleable. This explains why colleges and universities have always been the main place for national ideological and political education as well as party building. In order to keep pace with the times, practitioners in the field of ideological and political education in colleges and universities are obliged to change their working concept, re-structure and upgrade the established education mode, as well as double their effort in guiding students to help them grow in an all-rounded way. "Ideology and Politics of Course," which was proposed at the 2016 National Conference on Ideological and Political Work in College and Universities, has been the focal point of attention in the education world. Integrating ideological and political education with professional curriculum and putting their attribute of educating to good use allow us to chart courses for ideological and political education in the new age. Revolving around fostering character and civic virtue answers to having ideology-and-politics-permeated teaching to educate students, further stimulate their learning motivation, and enhance their awareness of respective majors throughout the process <sup>[1]</sup>.

The growing research on “Ideology and Politics of Course” mainly lies in mining the significance and ways of ideological and political elements in professional courses as well as the feasible approaches and precautions for their integration. This paper, grounded on literature review and the requirements of undergraduate education personnel training, probes into the “Simulation Electronic Technology Experiment” in terms of ideological and political teaching design. As a core compulsory course in the practice of undergraduate electronic information, it makes a crucial adjunct to theoretical teaching, shines on full-fledged experimental design, stresses the cultivation of hands-on ability and innovative consciousness, and goes hand-in-hand with theoretical teaching to ensure favourable teaching outcomes. With regard to this, the priority should be to extract the ideological and political elements of this highly practical basic course and integrate it into every link of the experimental design, thereby honing the skills of teachers in educating and equipping students with professional knowledge and skills as well as professionalism and craftsmanship. Based on the “Simulation Electronic Technology Experiment” course offered by Hainan Tropical Ocean University, we selected the classic single-tube common-emitter amplifier circuit experiment for an ideological and political teaching case design.

## 2. Course profile and academic analysis

“Simulation Electronic Technology Experiment,” as one of the earliest professional experimental courses designed for freshmen in Electronic Information, assumes a basic role in their studies for follow-up professional courses and attendance in technical innovation competition. **Table 1** lists the course profile.

**Table 1.** Hainan Tropical Ocean University’s “Simulation Electronic Technology Experiment” course profile

Course	Simulation Electronic Technology Experiment	
Type	Basics (required)	
Semester	2nd semester	
Major	Electronic Information	Vessel Electronics
Credits/hours	1/17	0.5/18
Prerequisite courses	“Circuit Principles,” “University Physics,” and “Advanced Mathematics”	
Follow-up course	“Digital Electronic Technology”	

As an aid to “Simulation Electronic Technology,” this independent course is more intuitive, practical, and comprehensive than the theoretical one. This earns it an important position and role when it comes to the cultivation of students’ application and innovation skills, engendering it a considerable practical link in the curriculum system of the Electronic Information major. The experimental framework of the course enables students to (1) be skilled in the use of common electronic instruments; (2) master the principle and performance index test method of the basic amplifier circuit in simulation electronic technology; (3) and grasp diverse experimental methods and means in virtue of Multisim simulation, experimental box wiring, and breadboards construction. The “Simulation Electronic Technology Experiment” course offered by Hainan Tropical Ocean University is delivered in 16 class hours, with each of the 8 experimental items lasting 2 class hours or 90 minutes. Within 90 minutes, the teacher has to explain the experimental principles and the use of instruments as well as set aside enough time for students to exercise their practical skills. The observation and analysis of teaching practices have revealed several issues: (1) unfocused targets have raised a higher threshold for implementation; (2) poor teaching contents have led to inconsistency; (3) outdated teaching methods, empty-talks, and talks that go awry are common <sup>[2]</sup>. On the other side, students (1) lack initiative, concentration, and efficiency; (2) are weak in teamwork and short of communication

skills; (3) are unable to carry out operation well and are in need of safety and environmental protection awareness. In response to the said problems, we integrated ideological and political elements into the course to redesign the teaching plan.

The case project of the classic transistor common emitter single tube amplifier experiment was arranged after “use of common electronic instruments,” in which the first basic amplifier circuit is introduced into simulation electronic technology. There are two reasons that this project was selected for the teaching case design

### **2.1. Bridging the preceding and the following**

Given a certain mastery of commonly used electronic instruments, there are follow-up courses for the performance indicators of the amplifier circuit. The simulation electronic technology experiment consists of three major steps. In Step I, students are encouraged to preview according to the experimental instruction book; in Step II, students must use the experimental box to connect the experimental circuit and test it by relying on their preview report; in Step 3, students are required to sort out the experimental data and compile the experimental report <sup>[3]</sup>. Despite the course’s ability to fulfil the teaching tasks within the limited time, there are still difficulties in arousing students’ learning interest, independent thinking skills, and innovative skills. The modular design of the experimental box saves students from trouble of picking components to build the circuit; they only need to plug and unplug the wires as well as adjust the adjustable resistance step-by-step to obtain the relevant voltage parameters and complete the task. They gain very little due to the limited access to components and a lack of intuitive practice <sup>[4]</sup>. To enable students to experience hands-on fun, breadboards are used. In that way, students can design or refer to the given circuit to select and build components according to specific conditions. The application of breadboards requires familiarity with its use and precautions. For instance, in the case of wiring, the negligence to arrange the components properly during wiring may lead to over-selected wires or a wire “overpass,” resulting in circuit failure. Tanglesome designs and amplifier circuit with many components may terrorize students with poor experience in breadboards, knowledge reserves, and skills. From this, the theme of the case design was set as “cultivating professionalism and inheriting the spirit of ingenuity—transistor common emitter single tube amplifier.” On the one hand, easy-to-medium levels of difficulty may be easier for students to get started so as to mobilize their learning enthusiasm and help them develop a habit of following standard operations; on the other hand, the transistor common emitter single tube amplifier is the most basic knowledge point and core content of “Simulation Electronic Technology.” Understanding and mastering such knowledge would have a direct impact on subsequent learning of other forms of amplifier circuits.

### **2.2. Integrating excavated ideological and political elements with course knowledge**

“Simulation Electronic Technology,” which is a basic course with strong engineering nature, is packed not only with various professional basic theories, but also rich ideological and political elements. In the transistor common emitter single tube amplifier course, efforts should be invested in determining the right way to bridge experiments and mainstream values organically so as to enable education in an all-rounded way through the mining of ideological and political elements from the objective, rigorous and meticulous scientific view, teamwork, exploration and innovation, future career development, and a sense of reverence for the system, with a variety of ideas.

### **3. Teaching plan design**

Students are still considered the main body of education in a teaching plan that incorporates ideological and political elements. In practice, it means to understand the actual situation of students, analyze their weak points, and carry out teaching and supplementation according to their needs. In addition, oriented by

employment, it increases certain educational links including students' professionalism and responsibility awareness, locates the entry point, and organically integrates ideological and political elements into teaching, thus "moisturizing and silencing" the ideological and political course and assisting students in forming the correct core values.

### **3.1. Teaching objectives**

#### **(1) Knowledge and skill objectives**

The transistor common emitter single tube amplifier experiment enables students to learn the debugging method of the amplifier's static operating point and the testing method of amplifier voltage magnification, input resistance, output resistance, and maximum undistorted output voltage so that they can analyze the effect of the quiescent operating point on the performance of the amplifier.

#### **(2) Process and method objectives**

The training of this experiment enables students to skilfully use the electronic equipment commonly applied in simulation circuit experiments; understand circuit schematic diagrams and reasonably arrange components on a breadboard; as well as learn to think independently, analyze causes, and solve problems.

#### **(3) Emotions, attitudes, and values**

Independent experiments are designed to enhance students' interest in professional learning, inherit the "spirit" of scientists, clarify duties and responsibilities of scientific and technological power, as well as establish a firm belief in striving for the cause of socialist modernization for life. All these are meant to improve students' safety awareness and cultivate their craftsman spirit of being rigorous, down-to-earth, conscientious, meticulous, and striving for perfection.

### **3.2. Key points and difficulties**

#### **(1) Key points**

Building a circuit with a breadboard teaches students to identify the pin arrangement of the crystal triode and the methods of connecting other components correctly so that they can use the connection points in the breadboard to arrange components reasonably and master the methods of measuring the dynamic parameters of the amplifier circuit.

#### **(2) Difficulties**

The modulation of the static operating point locates the causes for the distortion of the waveform.

### **3.3. Teaching methods**

Revolving around "proposing → dissecting → discussing → tackling tasks," guidance and enlightenment, independent inquiry, and group discussions are the three methods applied to stimulate students' interest in experimental courses and guide them to form correct socialist values with Chinese characteristics while cultivating their professional skills, so as to realize ideological and political education.

#### **3.3.1. Guidance and enlightenment**

Directed questions, such as "What are the main factors affecting the static operating point of transistor common emitter single tube amplifiers?" and "What are the methods for stabilizing the static operating point?", in the experimental preview stage enable students to think purposefully. These questions aim at clarifying the purpose of the experiment and guiding students to reflect on the theoretical knowledge learned.

#### **3.3.2. Independent inquiry**

In contrast to previous experiments, the emphasis is on strengthening students' independent exploration.

Different experimental circuits and parameters are given to the students for them to analyze the function of each component in the circuits during the preview stage, verify them on the Multisim software, and subsequently select discrete components to build experimental circuits on a breadboard. This helps students solve the problem of being unable to start when it comes to building a circuit for the first time [5].

### 3.3.3. Group discussion

In order to ensure that students understand the necessity of a stable static operating point [6], each group of students are required to complete the construction of two experimental circuits by themselves, and the teachers guide the students to observe the experimental phenomena caused by different experimental circuits. Each group analyzes and discusses the obtained experiment data and compiles an experimental report.

### 3.4. Teaching process

The teaching theme “cultivating professionalism and inheriting the spirit of ingenuity— transistor common emitter single tube amplifier” consists of pre-class preview, in-class teaching, and after-class data analysis, as shown in **Figure 1** (on the following page).

#### 3.4.1. Pre-class preview

Before the class, the experimental instruction book, breadboard, and precautions for the use of common electronic instruments are uploaded to the Wisdom Tree platform, and students are required to login to the platform to complete their pre-class tasks, covering PowerPoint (PPT) and practical operation videos as well as thought-provoking questions in the “Preview Part.” If students have any queries during online learning, they may communicate with their teachers through their respective QQ groups. Other than the preview tasks on the Wisdom Tree platform, the students also need to complete the construction of an experimental circuit in advance. First, the students were first divided into groups of four. The experimental circuit of 2 students is shown in **Figure 2**, and the experimental circuit of the remaining 2 students is based on **Figure 2**, but without the RB1, RE and CE components. All students were allowed to access the breadboard through the video uploaded by the teacher and use the components they received according to the experimental circuit shown in **Figure 2**. Through guidance via questions and group discussions before class, the students were guided to define the experimental principles and experimental procedures step-by-step in order to stimulate their learning interest and teamwork awareness.

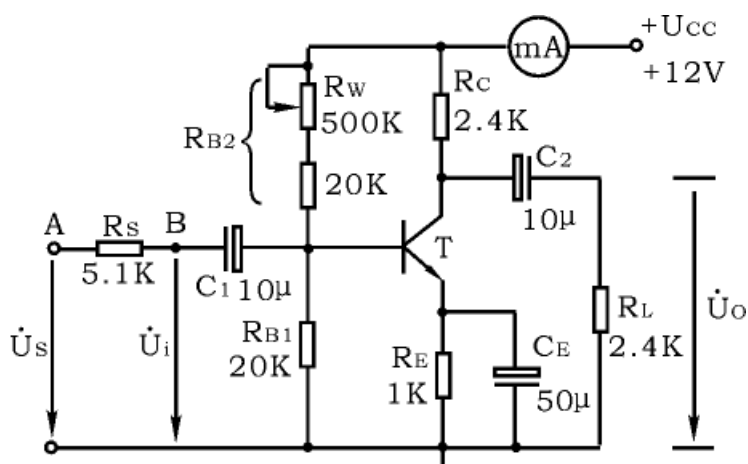

**Figure 2.** Common emitter single tube amplifier experimental circuit

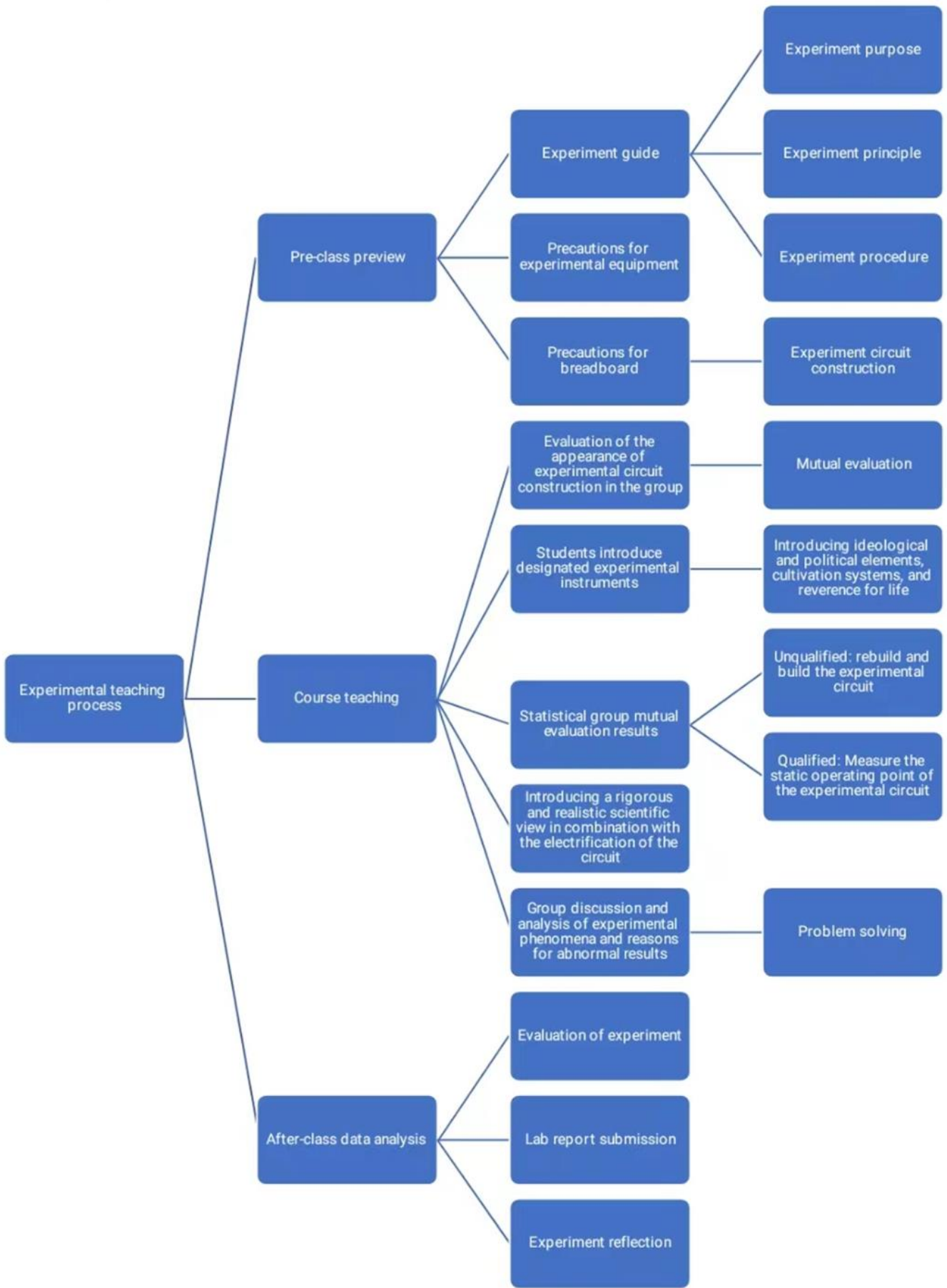

**Figure 1.** Experimental teaching process

### 3.4.2. In-class teaching

The main purpose of offline teaching is to check students' wiring and experimental outcomes. By checking the construction of the circuit, it helps to prepare students for the experiment. Teachers should remind students to standardize the use of instruments and the detection and elimination methods of common faults. The in-class teaching is specifically divided into five stages.

#### (1) Assessing the appearance of the built circuit

Students are required to assess the experimental circuit on the breadboard built by their partners within the group, such as whether the components and wires are close to the bread, *etc.* The scoring standards are shown in **Table 2**. Each group then compares their works with those done by other groups, so as to select the best one. The team with the highest score is awarded bonus points.

**Table 2.** Experimental circuit scoring standards

No.	Main content	Full score	Score
1	When the breadboard is turned upside down, no components or wires fall off.	10	
2	The power supply area is clearly divided, in which the red wire is used for positive power supply, whereas the black wire is used as the ground wire.	10	
3	The wires are tightly attached to the breadboard, and there are no components or wires straddling other components or wires.	20	
4	For connected wires, no bare wires are exposed. The direction of the wires is horizontal and vertical, and the distance is short.	30	
5	The layout is similar to the schematic diagram, and the layout is compact, neat, and pleasing to the eye.	30	
Full score		100	

#### (2) Enhancing students' safety awareness and emphasizing the importance of standardizing the use of experimental equipment

Each group is required to select a representative who will be assisted by the remaining members. The representative is required to introduce the experimental instrument and equipment designated by the teacher, focusing on the function, precautions, *etc.* Thereafter, the teacher summarizes the operation steps and key points of the reported instrument. Safety is no small matter. Non-standard operations, such as continuous power plugging and unplugging components, random connection of wires, and not turning off the instrument after the experiment, will all lead to laboratory safety accidents. Textbook experimental operation requirements and a warning video on 12 laboratory accidents that have occurred in colleges and universities in the past 10 years are explained and shown to the students. The vivid pictures educate students not to cause serious incidents by trying to save trouble or take it for granted as well as help them develop a sense of awe for rules and regulations and safety precautions.

#### (3) Assigning different tasks according to the self-evaluation and mutual evaluation results

Groups that scored less than 80 should analyze and rectify their experimental circuit in strict accordance with the scoring standards, while those with better performance should re-check whether the component pins and wiring are correct and then connect the direct current (DC)-regulated power supply to measure the static operating point of the experimental circuit.

#### (4) Introducing a rigorous and realistic scientific view based on the results of electrification of the experimental circuit

Years of teaching practices have concluded common misunderstandings in the inspection of experimental circuits shared by students: they generally believe that a circuit with correct external

connections is also well-connected internally. Hence, they often muddle through in the review of experimental circuits, fail to check whether each connection is correct or not, and even neglect checking whether the components connected to each pin of the triode are correct. Poor timely correction increases the likelihood of safety accidents. In order to eliminate such hazards, teachers should explain the “combination of two bombs” test in 1966, when a young soldier was worried about a 5 mm long white hair causing poor electrification of the projectile body, so he took great pains to pick out the white hair. As a result, he was commended by Qian Xuesen. This typical case of rigor and truth-seeking is often used to educate aerospace scientific and technological personnel and also students to treat science seriously, strictly, and rigorously. During experiments, only circuits with correct external wiring and up-to-standard internal connection can operate safely and reliably.

(5) Discussing and reporting the experimental phenomena and results in groups

Groups with no experimental phenomena or with abnormal experimental data should be guided to think about the possible reasons for the abnormality and encouraged to solve them themselves. In most cases, the main causes are device failure, wiring errors, and incorrect test methods. By following certain inspection steps, the students will eventually determine the cause of the failure. Offering discussions on troubleshooting during the experiment enables students to master certain solutions, cultivates their professionalism, and improves their innovation ability.

### 3.4.3. After-class data analysis

After in-class teaching, students are required to summarize, analyze, and process the experimental data. They should be able to sum up the experimental principles and procedures, analyze data errors, put forward their own opinions, and complete the experimental report. Through the analysis and discussion of data differences, they will be able to expand and deepen the experimental content as well as strengthen their independent thinking and research ability.

### 3.5. Teaching reflection

After incorporating ideological and political elements into the teaching plan, the goals of the Simulation Electronic Technology Experiment course are clearly defined: solidifying students’ professional knowledge and skills as well as moral education, which includes emotions, attitudes, and values. Materials of moral education are mainly sought from socialist core values, academic accomplishment, family and country feelings, and craftsman spirit to stimulate scientific and philosophical thinking among students. The teaching method of moral education has been reformed in view of being passive in reasoning by post-00 students. Through case analysis, group discussion, and scenario simulation, students are encouraged to participate in teaching activities. Teaching practice has registered significantly improved learning environment. Students have changed from having no way to begin with to a clear idea of experiments and knowing the next steps, rather than relying on their teachers to guide and troubleshoot for them. Despite the ideal design, an existing gap continues to separate the ideal from reality. As an example, during teacher-student interaction or group discussion, the participants’ engagement, is poor and the ideological and political elements introduced have yet to be unfolded at length due to time constraints; as a result, the students’ perceptions and understandings are limited. Moreover, the teachers have to improve their mastery of ideological and political theories. All these have adversely impacted the ideological and political teaching reform. As a follow-up, online questionnaire surveys should be included into the preview link, and teaching activities should be arranged according to the needs of the students. Furthermore, efforts should be doubled to extract the ideological and political elements from the main issues students are concerned about, so that they can resonate with the topics and thus show more interests. Teachers should take the initiative to participate in online and offline ideological and political theory training, make the best of both



worlds, and improve the existing moral education teaching methods as well as their own ideological and political education capabilities.

#### **4. Conclusion**

By interpreting and studying the characteristics of the school's "Simulation Electronic Technology Experiment" course, we have designed teaching cases; used teaching methods, such as guidance and enlightenment, independent inquiry, and group discussions; and organically integrated the excavated ideological and political elements into practices. In the actual process, we found that it worked by arousing students' learning interest and ability to analyze and solve problems as well as permeating the ideological and political work through the whole process of education and teaching. The pre-review stage, however, fell short of expectations on the group discussion report. This will be continuously improved in the later stage. The reform of practical teaching requires long-term efforts. The question here is how to organically integrate relevant knowledge with scientific development, social life, and other ideological and political elements, and naturally intersperse them in practical teaching and design teaching methods so as to stimulate active learning among students. This will be our main task in the future.

#### **Funding**

This paper was supported by the 2021 School-Level Education Reform Project of Hainan Tropical Ocean University Fund (RHYjg2021sz03).

#### **Disclosure statement**

The authors declare no conflict of interest.

#### **References**

- [1] Zhang J, 2020, Ideological and Political Teaching Practice and Exploration of "Simulation Electronic Technology" Course. *Light Industry Science and Technology*, 36(11): 187–189.
- [2] Chen L, 2022, Research on Teaching Case Design of "Circuit Principle" Course Based on the Ideological and Political Concept. *Industry and Information Education*, 5: 57–60.
- [3] Zhang Y, 2021, Case Study on Ideological and Political Teaching of Analog Electronic Technology Course. *Modern Commerce and Industry*, 7: 148–149.
- [4] Yan S, Cao L, 2021, Reform and Practice of Project-Based Electronic Technology Experiment Course. *China Modern Education*, 3: 54–56.
- [5] Zhang W, 2017, Exploration and Practice of DIY-based "Integration of Theory and Practice" in "Simulation Electronic Technology". *Journal of Ningbo Institute of Education*, 19(4): 96–99.
- [6] Tong S, Hua C, 2006, *Fundamentals of Simulation Electronics Technology*, Higher Education Press, Beijing.

#### **Publisher's note**

Bio-Byword Scientific Publishing remains neutral with regard to jurisdictional claims in published maps and institutional affiliations.